

PORTAGE & MAIN

Est. 1973

OUTDOOR WATER FURNACE WITH STOKER



**Super
Efficient
Fire Tube
Design!**

**Industrial
Quality
Controls!**

**WOW!
It Even
Has An
Ash Auger!**

**Warnock
Hershey
Approved!**

Tired of the rising cost of energy?

Heat multiple buildings with the most plentiful fuel on the planet – coal!

Outdoor water furnaces can be used for new building heating or easily integrated into your existing heating system.

They can be used with any forced air heat source already installed in the building (existing electric, gas or heating oil.) A simple fan coil radiator is installed in the furnace plenum. The furnace's existing fan blower distributes the heat. The fan blower is now controlled by a new thermostat, leaving the existing system intact for emergency back up. Heat is distributed evenly throughout the building.

You can also use a plate heat exchanger to connect to your existing indoor boiler. Boiler fluids are left intact and ready for emergency back up.

You can use a plate exchanger or sidearm to produce unlimited domestic hot water.

Coal stoker units provide dry air for assisted aeration or grain drying in a cost-efficient, effective manner.



INDUSTRY'S BEST WARRANTY:

- 10 year limited water jacket and burn-pot warranty
- 1 year warranty on electrical components

PROVEN TO BURN 1/3 TO 1/2 LESS

coal, wood pellets or bio-fuel pellets than conventional outdoor boilers

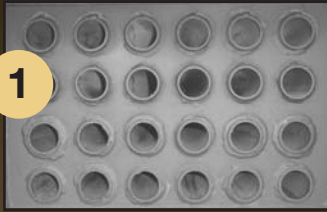

Last pass before exiting chimney

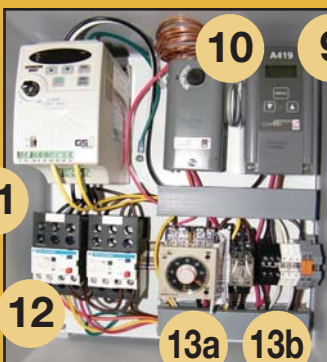

1. Super efficient double pass with reversing flow tube heat exchanger is standard on ML30, ML36 and ML42 stoker units. Very easy to clean from ground level with supplied brush.
2. Water-filled baffle provides first and second pass of heat exchanger, catches fly ash, enhances efficiency and makes for less cleaning.
3. Firepot and inside of water jacket made of 1/4" cold rolled W44 steel. Outer water jacket is 3/6" cold rolled W44 steel.
4. Round fire pot and water jacket – the strongest design for outdoor water furnaces:
 - Round eliminates side wall warping or cracking issues as metal expands very little because it expands around the total circumference. Very minute expansion.
 - Round means less stress on the welds compared to flat wall fireboxes.
 - Round designs require fewer welds/seams as compared to square fireboxes.
 - Round provides self circulation of water with no hot or cold spots.
 - Round gives the fire better flame contact with the metal.
 - Round has no square corners for ash to accumulate.
 - Round designs have been successfully engineered for over 200 years.
 - Round is stronger so it will be around longer.
5. Heat transfer water tubes ML 30 has three 3" diameter tubes. ML 42 has four 3" diameter tubes.
6. Heavy duty rotating self-cleaning high out put cast iron stoker head available in 18" or 22".
7. Combustion blower induces air through the specially designed slots in the stoker head.
8. Stoker in "Fire Keep Mode" controlled by adjustable time override to come on for 30 seconds every 30 minutes.
9. Johnson's digital electronic aquastat control is programmable to within one degree for temperature accuracy (no temperature creeping up) with large digital display.
10. High limit safety aquastat. (In the unlikely failure of the Johnson control, furnace can be operated with this manual aquastat.)
11. Proven Variable Frequency Drive (VFD) speed control feed rate. High quality fan comes with overload protected, ball bearing motor, capacitor started for long life.
12. Adjustable drive overloads for fan and stoker. No need for shear pins.
13. Burn back protection provided by:
 - a) Overloads provide protection by parallel wiring that insures stoker and fan will stop if overload/jam occurs.
 - b) Timer device.
 - c) Long auger length (Standard 10' and special order 12').
14. Heavy-duty, industrial quality Bonfiglioli Gear Box Drive. CSA approved heavy-duty 1/4 HP AC 220 Volt 3-Phase Leeson drive motor (inverter rated). All the advantages of a 3 phase motor without requiring 3 phase power feed. Long life, reversible motor with low electrical consumption.

~ TESTIMONIAL ~

I have been using my first Portage & Main for six seasons. I am very happy with the savings. I heat a 20,000 sq ft building with 20 ft ceilings, called the Emerson Duty Free Shop. Our monthly heating bills used to be close to our now yearly heating bills using coal. The Portage & Main outdoor water furnace/boiler is an efficient design. I have been impressed enough to purchase a second unit for another location. I have been involved with alternative burning units for over 15 years and see the quality manufacturing and design for efficiency in the Portage & Main. Most likely, I will be purchasing a third unit for another location. This is a very efficient unit. This is an excellent hot water system that is very cost efficient. I think you have a very good unit. I am happy it is working perfect. I would recommend it to anyone with a larger heating requirement.

~ Michael R. - Manitoba, Canada

VIRTUALLY SMOKELESS

Warnock Hershey UL Certified



15. Automatic 5' ash removal auger increases life of stoker head as it is not rotating in ash build up.
16. Top quality industrial solid rope gaskets on fire door heat exchanger and cleaning access doors keep the unit airtight.
17. Fire door insulated with Roxul insulation rated for 2200 degrees F.
18. Heat exchanger door is refractory brick lined.
19. Fuel feed hopper designed to fit under hopper bottom bin. Eliminates the need of a cross-over auger, costs and maintenance. Auger made with 3/8" flighting.
20. Indoor hopper available in custom sizes totally eliminates coal freezing problems
21. Easy to read convenient float level. No sight glass of tubing to discolor. Breather tube and filler pipe's unique design reduces evaporation. Low water shut-down safety switch on stokers.
22. Powder coated finish on the one-piece roof has no trims to rust or deteriorate.
23. Chimney comes out back of furnace below water level. This prevents stack corrosion.
24. Top quality mirror-like paint on the rest of the furnace.
25. "PORTAGE & MAIN" is proudly stamped into every unit.

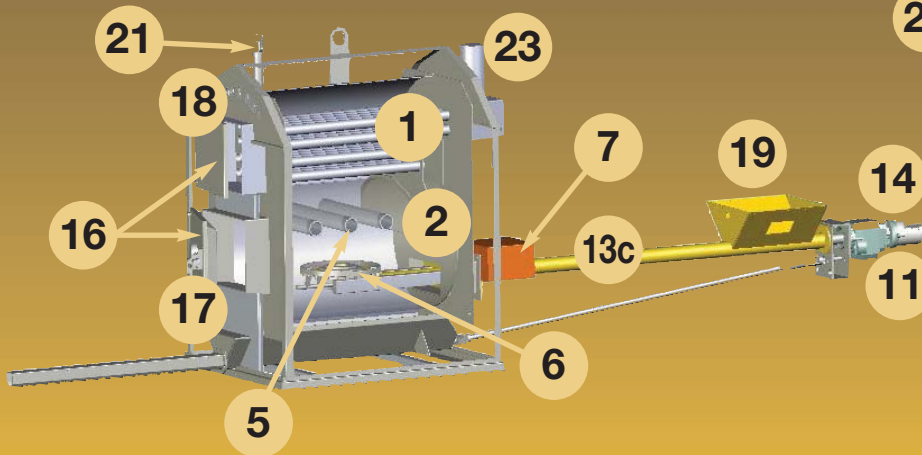
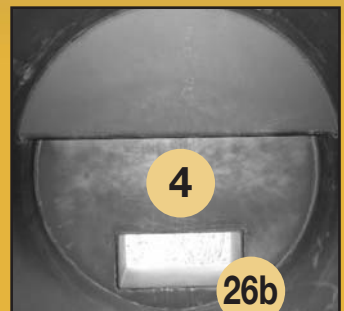

26. ML30 Options:

- a) Highly efficient multi-pass heat exchanger with 180 degree turns. Designed for efficiency and greatly reduced fly ash emissions. Very easily cleaned from ground level.
- b) Stoker can be easily removed and grates and fan installed to burn wood.

Portage & Main Outdoor Water Furnaces have a long history of great performance thus earning them the name of "The Original Efficient One Since 1973" Round firepot/water jackets and 1/4" cold rolled steels means less risk of warping related problems. W44 cold rolled steel has the same corrosion properties as boiler plate. It is known for being a very "uniform" steel, ideally suited to forming without fatiguing. It is easy to shear, break and is "welder friendly."

All parts are laser cut for precision fitting which also allows for the bevel to be accurately filled when welding. The weld strength is increased by boiler/pipeline style double welds which take more time but is well worth it as it results in total penetration which helps prevent weld corrosion, cracking and pin holes leaks.

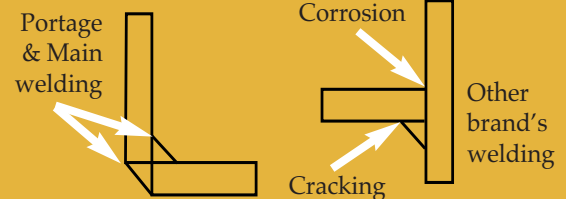



30,000 sq ft factory heated by Portage & Main Outdoor Coal Stoker.



Large 20,000 sq ft duty free shop on US/Canada border heated by coal.



Portage & Main Coal Stoker heats 15,000 sq ft character home.

~ TESTIMONIALS ~

We live on a windy mountain in NW Pennsylvania. We heat a 10,000 sq ft home and 9,800 sq ft garage. We had been burning 2 tri-axle trailers of wood and 28 tons of hard coal. We installed a Portage & Main ML42 coal stoker. We estimate we will now burn less than 20 tons of coal and no wood with its related work. Now we can be away from home without needing to tend a "needy" outdoor boiler. We are staying consistently warm with a lot less work. It is smokeless. We recommend this coal stoker system to anyone. **- Rick M. - Pennsylvania, USA**

We purchased a Portage & Main fully self-contained coal burning unit in 2006. The built-in coal hopper eliminates potential coal freezing problems. It has not had any problem heating a 10,000 sq ft shop in Northern Alberta. We have not had any problems with the unit. The drive system is heavy-duty and the efficiency seems quite good. This is the second coal heating system we have purchased through PA Hydronic Heating Solutions as we also heat our riding arena using coal and find it also very economical. We have used in-floor heating and special Shinook ceiling hung air handlers for great comfort. This was also supplied by PA Hydronic Heating Solutions. **- Richard H. - Alberta, Canada**

Portage & Main Outdoor Water Furnaces with Stokers... a size for every need, large or small

Three Models to Choose From:	ML 30*	ML 36*	ML 42
HEIGHT (inches)	72	77	98
WIDTH (inches)	48	53	59
LENGTH (inches)	57	57	57
WEIGHT (pounds)	2,000	2,200	2,850
STOKER WEIGHT (pounds)	400	600	600
FIRE BOX SIZE (diameter x length)	30" x 44"	36" x 44"	42" x 44"
HEATING AREA (square feet)	up to 10,000	up to 20,000	up to 30,000
WATER CAPACITY (U.S. gallons)	120	190	240
EST. BTU OUTPUT	up to 400,000	up to 600,000	1,000,000 plus

* Available with trough style exchanger. Can burn wood by taking out stoker and adding fan.

Gives you peace of mind, safety and convenience...

- No fire hazard inside your home
- No messy fuel, ashes or smoke in your home
- No increase in fire insurance premiums unlike indoor stoves
- No risk of carbon monoxide poisoning
- The water temperature is electronically controlled with an aquastat that has water temperature display features
- Surfaces are insulated or water cooled for safe operation
- Automatic feeding from the stoker supply bin
- Automatic ash removal

Efficient and dependable...

- Portage & Main Outdoor Water Furnaces have proven to be very efficient
- It uses 1/3 to 1/2 less fuel than most conventional boilers
- The built-in four pass heat exchanger maximizes heat extraction from the flue gases

Provides societal and environmental benefits...

- It minimizes the use of expensive fossil fuels such as natural gas, oil or electricity

Manufacturers reserve the right to make changes or modifications to products. Brochures are updated regularly, however for the most current information please see the website www.portageandmainboilers.com

"The Original Efficient One Since 1973"

North American Portage & Main Outdoor Water Furnace Distributor

HEAT SMART PLUS

R.R. #5, Site #16, Box #114

PRINCE ALBERT, SK S6V 5R3

1-800-561-0700

www.portageandmainboilers.com



Your Authorized Portage & Main Dealer

Financing available at participating dealers.